

TECHNICAL SPECIFICATIONS - TBSI580

GENERAL SPECIFICATIONS:

CABINET and WATER RESERVOIR

The cabinet and water reservoir components are injection moulded structural foam polypropylene (Permatuf®). The cabinet and reservoir are UV stabilised and corrosion free. The major components clip together without additional fasteners.

FAN

The Superstealth fan is a multi blade assembly made from injection moulded glass reinforced polypropylene. The blades are aerofoil shaped. The fan is mounted directly to the motor shaft by means of a set screw.

FAN MOTOR

The fan motor is a single phase inverter motor, with die-cast fully enclosed aluminium frame. The motor and fan assembly are supported on an injection moulded glass reinforced ABS venturi ring via a glass reinforced polypropylene motor mount. The fan motor is fitted with a polarised plug for quick removal and replacement.

AutoWinterseal™

The AutoWinterseal™ consists of two semi-circular, polypropylene blades, hinged and counterbalanced, to open automatically when the fan is activated, and to close when the fan is switched off. Latching is by magnets to steel striker plates.

MAIN CONNECTION DUCT

The main connection duct must incorporate a raw edge or safe edge to avoid fouling of the AutoWinterseal™.

ELECTRICAL CONTROL

The electrical control box is pre-wired within the cooler. A 2 metre long power supply cord is supplied as standard. Provision is included for plug-in connection of drain valve and solenoid kits. A 10 amp anti-surge fuse is fitted to the underside of the enclosure.

THERMOSTAT CONTROL

TBSI model coolers feature the MagIQcool® controller, for full automatic control. The MagIQtouch® controller is available as an alternative option. Connection of either controller to the control box is via the 20 metre low voltage cable supplied.

WATER CONNECTION

Water supply connection is via a flexible connector which is terminated with a 1/2" BSP compression nipple. An isolating valve must be fitted adjacent to the cooler for service. A drain-down facility is required in areas subject to freezing.

The patented water distribution system is an integral part of the lid, and can be readily viewed from the top by removing the pad frame assembly.

COOLING PADS

Cooling filter pads are Black Opal™ Mini-Cell^ Chillcel® fabricated, honeycomb, high efficiency type.

COLOUR

SuperStealth TBSI series coolers are available in one colour, "Slate Grey".

[^]patent pending

AIR FLOW PERFORMANCE SUMMARY

Model	Airflow L/s (m ³ /h) @ 80Pa	Motor W	Air Flow - L/s (m ³ /h) versus Static Pressure (Pa)							
			0	40	80	120	160	200	240	280
TBSI580	3030 (10910)	950	3400 (12240)	3240 (11660)	3030 (10910)	2740 (9860)	2450 (8820)	2140 (7700)	1710 (6160)	1000 (3600)

It is a policy of Seeley International to introduce continual product improvement. Accordingly specifications are subject to change without notice.

TECHNICAL SPECIFICATIONS - TBSI580

Specification		TBSI580
Airflow	Actual @ 80Pa (L/s)	3030
	Actual @ 80Pa (m³/h)	10910
Cooling Capacity	kW*	18.4
Evaporative Efficiency	Percentage (%)	91.5
Power Consumption (total)	Power - Max (W)	1500
	Current - Rated (A)	7.0
	Energy Efficiency Ratio (EER)	12.3
Power Supply	Voltage / Phases / Hz	200-240/1/50
Controller	Type	Digital
Fan	Type	Axial
	Diameter - External (mm)	534
Motor	Type	Inverter
	Speed - Max (rpm)	1700 VAR
	Output Max (W)	950
	Current Max (A)	6.3
	Overload	One Shot Fuse
	Enclosure Rating	IP24
Pump	Type	Centrifugal
	Motor	Synchronous
	Current - Rated (A)	0.25
	Flow Rate (L/min)	21
	Voltage / Phases / Hz	230/1/50
	Overload	Thermal One Shot Fuse
	Enclosure Rating	IPX4
Cooling Pad Chillcel	Size (mm)	850x526Hx120 (4 pads)
	Pad Area (m²)	1.79
Water	Tank Capacity (L)	23
	Inlet (mm/inches)	12.7mm / ½" male BSP
	Drain (mm/inches) Configurable to local requirements	40mm / 1½" male BSP
Shipping	Dimensions (mm) including pallet	1150x1150x902H
	Volume (m³)	1.20
	Mass - Shipping (kg)	71
	Operating (kg)	94
Connecting Duct (raw edged)	Length & Width (mm)	550x550

* Cooling capacity measured to Australian Standard AS2913-2000, ambient of 38°C dry bulb & 21°C wet bulb, with room exit temperature of 27.4°C.

Model	Speed	Radiated Sound Power Level (dB(A) re 1pW) Octave Band Centre Frequency							Total Sound Power dB(A) re 1pW
		125Hz	250Hz	500Hz	1kHz	2kHz	4kHz	8kHz	
TBSI580	10	62	62	70	72	70	62	53	76



Air flow performance has been measured in accordance with Australian Standard AS2913:2000 "Evaporative Air Conditioning Equipment" by Meridian Laboratories Pty Ltd

*Meridian Laboratories is registered by the National Association of Testing Authorities, Australia. The tests reported herein have been performed in accordance with its terms of registration. Registration No.: 3697

TECHNICAL SPECIFICATIONS - TBSI580

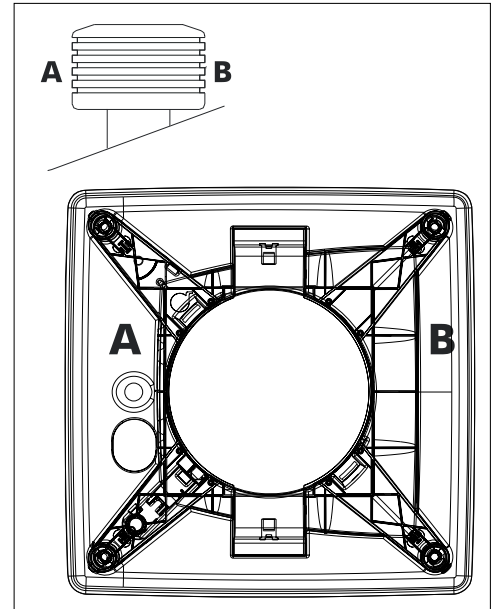
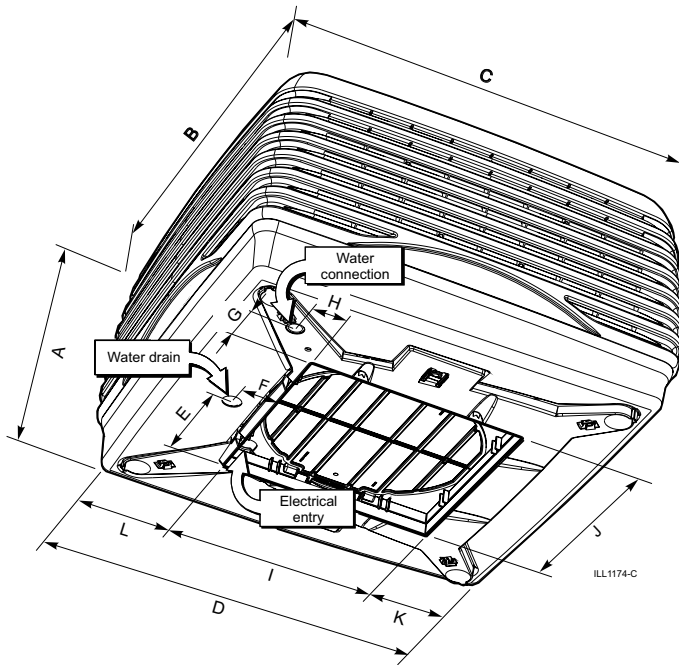

Model	A	B	C	D	E	F	G	H	I	J	K	L
TBSI580	835	1150	1150	1080	275	95	82	82	555	555	249	279

Dimensions are in mm.

FAN CURVE (m³/hr)

